



TWISTER[®]

3-ARM

WAIST HEIGHT

TURNSTILES

SINGLES & DOUBLES

BoomGate[®]
Systems (PTY) LTD

Reg.No. 98/23505/07 Engineering Access Control





MARKET LEADER

- High performance ultra quiet rotation.
- Used for reliability, ultra high traffic flow, virtually no maintenance.
- Exported worldwide.

APPLICATIONS:

- To control high volumes at medium risk areas.
- Most suitable: office receptions, colleges, health clubs and stadiums.
- Suitable for exterior and interior or any abnormal conditions.

CONFIGURATIONS:

- Single Twister® Euro Style
 - Double Twister® Euro Style
 - Single Twister® Slimline
 - Double Twister® Slimline
- Mild powder coated
 - Stainless steel 304
 - Stainless steel 316

SECURITY LEVEL RATING: (LOW / MEDIUM / HIGH / ULTRA SECURE)

TYPE	TWISTER®	LOW	MEDIUM	HIGH	ULTRA SECURE
3-ARM	SINGLE	X			
3-ARM	DOUBLE	X			

DEFINITION:

Security rating is based on when the turnstile is in the locked position.

Level of security is based on entry through the turnstile without unlocking the rotor and the use of access control system.



DID YOU KNOW:

- Your turnstile comes with a 7 year mechanical warranty, the first in S.A. That is how confident we are in our product.
- You will not pay for any mechanical component in your 7 year warranty period.
- BGS has been manufacturing turnstiles for 16 years.
- Our customers range from world renowned blue chip corporations to small single users.
- BGS turnstiles are supplied complete with control panel. The control panel is suitable for battery back up. Batteries are not included. Need 2 x 7.5 amp/hour. Battery back up option comes standard on all our models at no extra cost.
- The control panel also has a 12V output for LED indicators.
- All mechanical components are die cast, CNC machined and laser cut to the highest precision and quality.

SPECIAL FEATURES TO THE TWISTER® RANGE:

- Unique “keyless square shaft®” design.
- This new design in our shaft is what sets us apart.
- Designed for long-lasting reliability.
- Rotor returns to locked position after every rotation.
- Modular 11 pin programmable logic with LED indicators.
- Control panel comes standard with 12V and 24V DC output.
- Mechanical key override for both directions.
- Solenoids are rated 100% duty cycle for trouble free operations.
- Case hardened locking mechanism.
- Maintenance free mechanism.
- Factory tested recorded serial numbers.
- Quiet locking and unlocking mechanism.
- Manufacturers warranty:
 - **7 year mechanical warranty, first in S.A.**
 - **1 year electrical warranty**
- Zinc plated mechanism for corrosive protection.
- Mechanism comes with a dust cover for extra protection, noise reduction.
- No midway locking or trapping in an event of power failure.
- Hydraulic Damping Systems: All Twisters® are fitted with hydraulic damper to slow rotor down before locking.

TECHNICAL SPECIFICATION:

Power:	220V AC \pm 5%
Frequency:	50Hz
Power Consumption:	50W for single turnstile and 100W for double turnstile
Logic Voltage:	24V DC, 12V available on request
Solenoids Voltage:	24V DC, 12V available on request
Turnstile Dimensions:	See drawings overleaf.
Rotor arm configurations:	3-arm = 120°
Rotor arms:	38mm Round Tube fixed arms
Weight:	Euro Style Single 80kg Double 110kg Slimline Single 84kg Double 120kg
Package Size:	Euro Style Single = 1085mm x 540mm x 500mm Double = 1085mm x 540mm x 660mm Slimline Single = 1230mm (L) x 1090mm (W) x 330mm (H) Double = 1200mm (L) x 1090mm (W) x 480mm (H)
Export:	Turnstile arms can be disassembled and packed into purpose made pallets for export. Materials are treated for export.

SYSTEM COMPATIBILITY:

Boomgate Systems turnstiles are compatible with any access control system, time and attendance system or ticketing system. Only requires a n/o voltage free input trigger set for half a second.





AVAILABLE OPTIONS:

Single/Dual Direction Rotation:

Electronic control in one direction and mechanical in opposite direction.

Electronically controlled in both directions.

Mechanical control in both directions by means of key lock.

Power Locking Options:

Fail secure lock on power failure.

Fail safe unlock on power failure.

Fire Evacuation Option:

Rotor will free turn when input is triggered. (It is not recommended to use a turnstile for emergency evacuation).

Battery Back Up:

Battery back up comes standard with all our turnstiles
Batteries not included. Requires 2 x 7aH batteries to be connected in series. A third battery can be added for 12V back up.

± 1000 transactions on fail secure mode.

± 60 minutes on fail safe mode.

Indication LED:

The turnstile can be fitted with red/green walking man to indicate go or stop.

Accessories available on request:

Push buttons, coin acceptors for paid access control,
random search selectors.

Material options:

Mild steel powder coated with textured exterior UV resistant powder.

Granite top cover available on request for Slimline Twister®
304 stainless steel brushed.

316 stainless steel brushed for extreme conditions.

Standard colours for M/S powder coated are Black.



TWISTER® WAIST HEIGHT TURNSTILES



TWISTER® EURO SINGLE

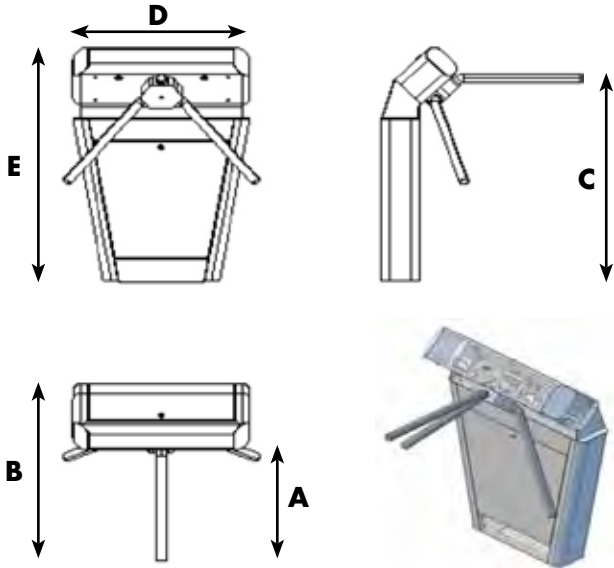

TWISTER® SLIMLINE SINGLE

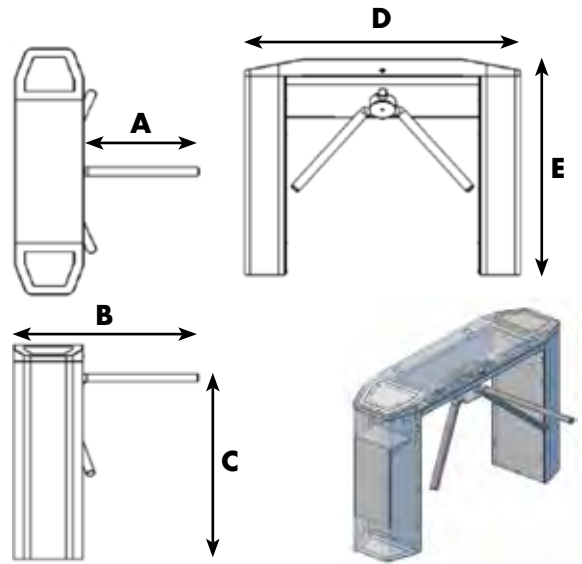

TWISTER® EURO DOUBLE

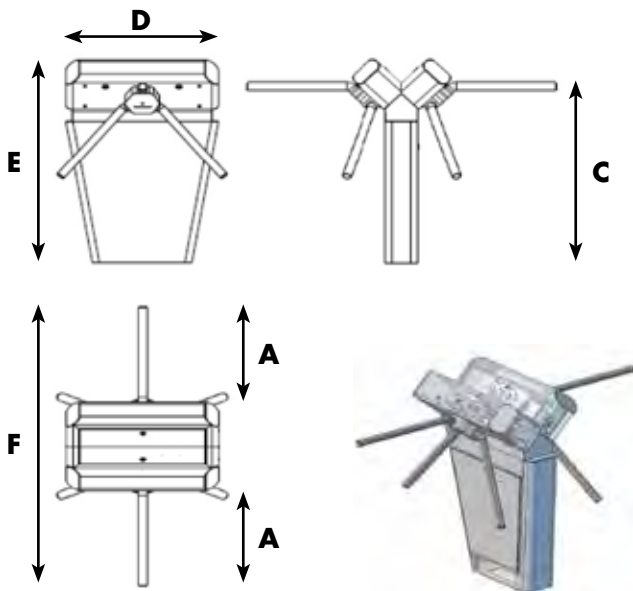

TWISTER® SLIMLINE DOUBLE

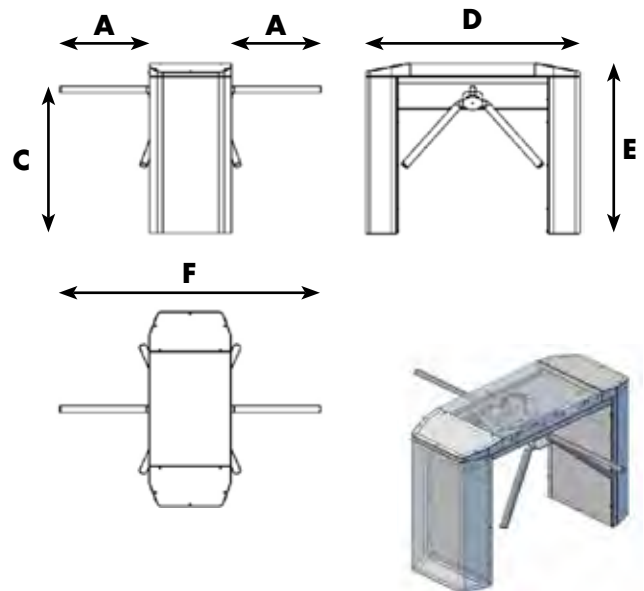

A	Arm Length	505mm
B	Overall Width	840mm
C	Arm Height	955mm
D	Unit Depth	715mm
E	Overall Unit Height	1080mm
F	Overall Width	1520mm

A	Arm Length	505mm
B	Overall Width	805mm
C	Arm Height	910mm
D	Unit Depth	1200mm
E	Overall Unit Height	1050mm
F	Overall Width	1470mm

Due to continuous improvement, products and design are subject to change without notice.

EURO STYLE SINGLE WAIST HEIGHT 3-ARM

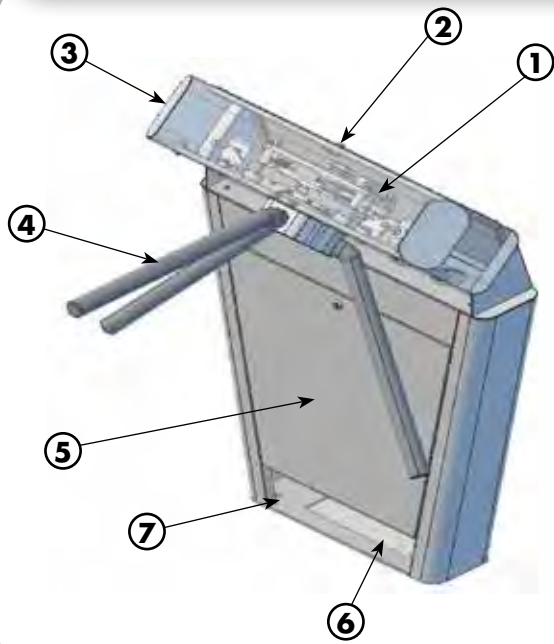

SINGLE SLIMLINE WAIST HEIGHT TURNSTILE

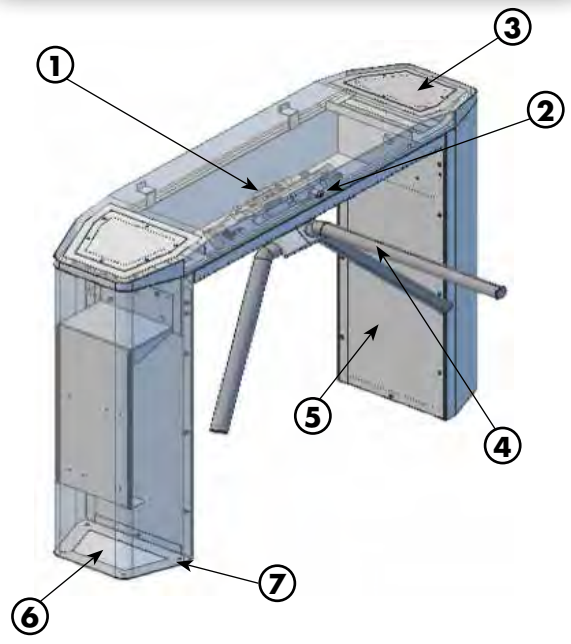

EURO STYLE DOUBLE WAIST HEIGHT 3-ARM

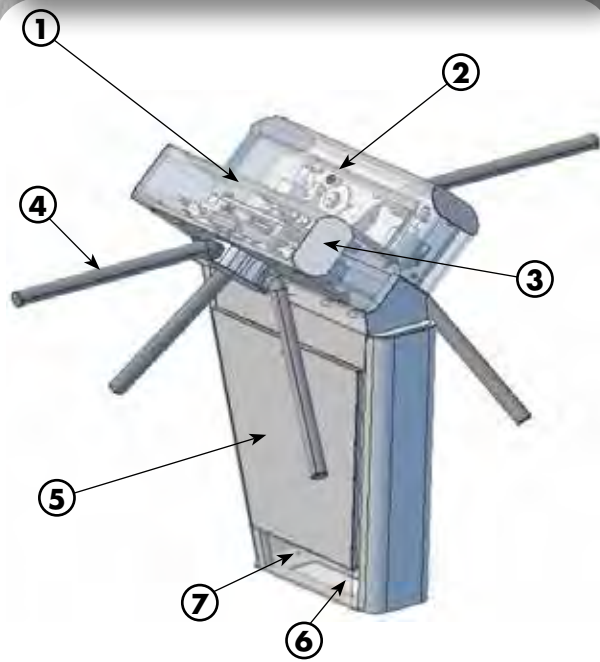

DOUBLE SLIMLINE WAIST HEIGHT TURNSTILE

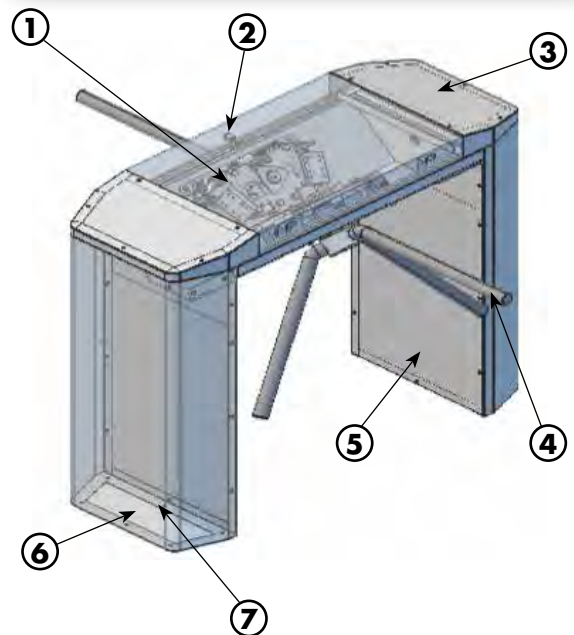

KEY

1. Mechanism and Electronic control, C/W hydraulic damping & mechanical key override for free turn.
2. Lockable and removable lid.
3. Reader mounting position.
4. 38mm round tube stainless steel arms.
5. Removable bottom cabinet covers.
6. Cable entry.
7. Floor fixing position.

BoomGate[®]
Systems (PTY) LTD
Reg No. 98/23505/07 Engineering Access Control



JOHANNESBURG BRANCH: Tel: +27 11 674 4441 • Fax: +27 11 674 4450 • Email: boomgate@global.co.za

18 Minerva Avenue, Leaglen, Florida, Roodepoort, SOUTH AFRICA

CAPE TOWN BRANCH: Tel: +27 21 551 0849 • Fax: +27 21 551 8627 • Email: salesct2@boomgatesystems.co.za

Unit 2 Crest Park, 12B Longclaw Drive, Montague Gardens, Cape Town, SOUTH AFRICA

www.boomgatesystems.co.za

Manufacturers & Suppliers of:

- Traffic Barriers
- High Security Spike Barriers
- Road Blockers
- Turnstiles
- Security Booths
- Pedestrian Barriers
- Paraplegic Gates
- Speed Gates
- Bollards
- Goosenecks
- Magnetic Locks
- Metal Enclosures
- Rubber Islands